



CoMoveIT

CoMoveIT Smart

Specialty Input Head-Foot Control Device for Powered Wheelchairs



CoMoveIT Smart
Instructions for Use



How to contact CoMoveIT

CoMoveIT NV

Baron Ruzettelaan 5/1.1

Assebroek (Bruges), 8310

Belgium

Phone: +32 477 880 175

Email: info@comoveit.com

Website: www.comoveit.com



CoMoveIT Smart

Specialty input head-foot control device for powered wheelchairs

Produced and published by CoMoveIT, Belgium

Version 1.3, 2024-01-24

Article no.: CM0001-IFU-EN

Table of Contents

How to contact CoMoveIT	2
Important information about these Instructions for Use	6
Serious incidents	7
Support, scrapping and spare parts	7
Warranty	8
Safety Rules.....	9
General.....	9
Warning labels	9
General Warnings and Cautions	10
List of Symbols in product labels	12
Unique Device Identifier Information	14
Intended Use	14
Contraindications.....	15
Environmental Conditions	15
Device Description.....	15
General.....	15
Head array adjustment mechanisms	16
Head array - right and left head pads	18
Head array - back head pad.....	19
Foot pads	19
Dummy Foot Pad.....	20
Electronic Control Unit (ECU).....	20
CoMoveIT Smart installation	21
CoMoveIT Smart removal.....	24
Configuration	24
R-net configuration.....	24
Operating Instructions.....	25
General.....	25
Configurations	26
Using your CoMoveIT	28
Maintenance	31



Cleaning	32
Storage	32
Troubleshooting	33
R-net Error Codes	33
Summary	35
Technical specifications	37



Important information about these Instructions for Use

We congratulate you on your choice of a CoMoveIT product. Our goal is for you to be satisfied with your choice of both vendor and product.

We sincerely apologize for any inconvenience caused, as the instructions for use are currently not accessible to visually impaired individuals.

Before using this product, it is important to read and understand the content of these Instructions for Use and in particular the Safety Instructions. It is unsafe to start using the device before reading the Instructions for Use.

The Instructions for Use clarify the functions and characteristics of CoMoveIT Smart and how you can use it in the best way. They also contain important safety and maintenance information, as well as describe possible issues that could arise during use.

Always keep these Instructions for Use handy in connection with your wheelchair.

It is also possible to obtain information concerning our products on www.comoveit.com.

All information, pictures, illustrations, and specifications are based upon the product information that was available at the time that these Instructions for Use were printed. Pictures and illustrations that are found in these Instructions for Use are representative examples and are not intended to be exact depictions of the various parts of CoMoveIT Smart. CoMoveIT reserves the right to make changes to the product without prior notice.

Ordering of documentation

If you need another copy of this Instruction for Use document, it can be ordered from CoMoveIT via info@comoveit.com, by asking for item CM0001-IFU-EN.

The Instruction for Use documents are also available for download on:

www.comoveit.com.

Serious incidents

SERIOUS INCIDENTS

In case of adverse or serious incidents causing human injury, you should contact CoMoveIT at vigilance@comoveit.com or your local distributor as soon as possible.

Always state the serial number of the device when contacting CoMoveIT to ensure that the correct information is provided.

Support, scrapping and spare parts

TECHNICAL SUPPORT

In the event of technical problems, you should contact your local distributor or CoMoveIT at +32 477 880 175 or via info@comoveit.com.

Always state the reference and serial number of the device when contacting CoMoveIT to ensure that the correct information is provided.

SPARE PARTS & ACCESSORIES

Spare parts, consumables and accessories must be ordered through your local distributor.

SCRAPPING CoMoveIT Smart

Contact your local distributor or CoMoveIT for information about scrapping agreements in force.



Warranty

WARRANTY

CoMoveIT warrants CoMoveIT Smart to be free from defects in material and workmanship for a period of two years under proper use, care, and service.

All warranties will cover parts only and do not extend beyond the initial purchaser from an authorized CoMoveIT distributor. Normal wear and tear and consumables are always excluded from the warranty.

Commencement of Warranty Period

The warranty of CoMoveIT Smart begins on the date that the product is first delivered to the customer, or forty (40) days from the date that the product is shipped to the authorized distributor by CoMoveIT, whichever comes first.

Repair or Replacement

For warranty service, customers should contact the authorized distributor from whom the product was purchased. In the event of a defect in material or workmanship, the distributor must obtain a return authorization number from CoMoveIT, and the product must be shipped to a service center designated by CoMoveIT. The distributor will repair or replace any product covered by the warranty. This warranty does not include any labor charges or shipping charges incurred in replacement for installation or repair and any such product.

WARRANTY

Amendments

No person is authorized to change, extend, or waive the warranties of CoMoveIT. An original document, countersigned by the party or parties concerned must be received by CoMoveIT before any amendment takes effect. This warranty shall be extended as necessary to comply with state laws and requirements.

Voiding of Warranties

The above-mentioned warranties are depended to proper use, maintenance, and care of the product. The warranty will be void if the product has been used improperly or if it has been repaired or any part replaced by persons other than CoMoveIT or an authorized CoMoveIT distributor.

The addition of equipment, peripherals or features that are not manufactured or recommended by CoMoveIT could affect the intended function of CoMoveIT Smart product.

The use or installation of equipment not issued or accepted by CoMoveIT invalidate the warranty.

	<p>CoMoveIT NV, Baron Ruzettelaan 5/1.1, 8310, Assebroek (Bruges), Belgium</p> <p>www.comoveit.com</p> <p>info@comoveit.com</p> <p>+32 477 880 175</p>
<div style="border: 1px solid black; padding: 5px; display: inline-block;"> CH REP </div>	<p>SKS Rehab AG, Im Wyden 3, CH-8762, Schwanden, Switzerland</p>
<p style="text-align: center;">UK Responsible Person</p>	<p>UK REP MED Limited, Unit D Crondall Place, Coxbridge Business Park, Alton Road, Farnham, GU10 5EH, United Kingdom</p>

Safety Rules

General

CoMoveIT Smart head-foot specialty control device for powered wheelchairs is intended to be fitted to any powered wheelchair equipped with R-net electronics.

Incorrect use may lead to risk of injury to the user and damage to the wheelchair or other property. In order to reduce these risks, it is imperative that you should read through this Instructions for Use carefully, paying particular attention to the safety instructions and the warning texts.

Any unauthorized use of CoMoveIT Smart may lead to increased risk of accident. Follow the recommendations in the Operation section carefully in order to prevent the risk of accidents from use.

All alterations to and interventions in the vital systems of CoMoveIT Smart must be performed by a qualified service engineer. In case of doubt, always contact CoMoveIT or a qualified service engineer of your local distributor.

All information and specifications included in this instruction manual applied at the time of delivery of this product. As CoMoveIT undertakes continuous development and improvement, we reserve the right to make changes without prior notification.

Warning labels

These Instructions for Use, utilize the following warning labels, which are intended to draw attention to situations that could lead to unwanted problems, personal injury, or

damage to the wheelchair, etc. Read the Instructions for Use carefully to reduce risks associated to the device.



CAUTION!

Please use caution where this symbol appears. A situation could result in minor or moderate injury.



WARNING!

Please use extreme caution where this warning symbol appears. Failure to observe warnings can lead to serious injury or death and property damage, including damage to the wheelchair.

General Warnings and Cautions



WARNING!

Do not attempt to operate a powered wheelchair with the CoMoveIT Smart without the assistance and training from a healthcare professional qualified for these activities. Do not attempt to independently operate a powered wheelchair with the CoMoveIT Smart until a qualified healthcare professional gives you the permission to do so.



WARNING!

The wheelchair must be fitted with an emergency stop function that is within the reach of the attendant.



WARNING!

Stop using the device immediately if operating problems occur.

**WARNING!**

The wheelchair must be fitted with an emergency stop function that is within the reach of the attendant.

**WARNING!**

The device may inadvertently activate when exposed to rain or excessive moisture. This may cause the wheelchair to drive in an unintended manner, creating a dangerous situation.

**WARNING!**

Do not press the head pads and foot pads of your device using sharp objects. This will affect the operation of the force sensor arrays.

**WARNING!**

Do not use the footpads of the system if the top layer is damaged or worn out. Clearly visible and palpable damage indicates the need for replacement. The device may inadvertently activate when the footpad top layer is damaged. This may cause the wheelchair to drive in an unintended manner, creating a dangerous situation. Replacement can be easily done by following the instructions provided by technical personnel.

**CAUTION!**

CoMoveIT accepts no liability for personal injury or property damage that may arise from the failure of the users to follow the indications, recommendations, warnings, cautions, and instructions given in this Instructions for Use document.



CAUTION!

Obsolete parts of CoMoveIT Smart should be responsibly disposed according to local recycling regulations.



CAUTION!

Electromagnetic Compatibility (EMC) requirements

The electronics of CoMoveIT Smart may be affected by external electromagnetic fields (e.g. mobile phones). The electronics of CoMoveIT Smart also emit electromagnetic fields that could affect surrounding devices. The EMC threshold values are laid down in harmonized standards under Regulation (EU) 2017/745. CoMoveIT Smart meets or exceeds threshold values for electromagnetic immunity. CoMoveIT Smart meets or is below the limit threshold values for emitted electromagnetic fields.





CAUTION!









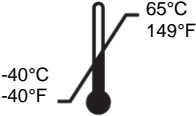
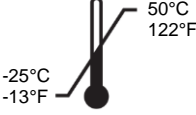

Maximal forces on the head

The head array of CoMoveIT Smart may be affected by extreme force applied by the user. The maximal forces applied in the head array in any direction are specified by CoMoveIT to be up to 205 Newtons.

List of Symbols in product labels

All symbols used in the labeling of CoMoveIT Smart are in accordance with ISO 15223-1:2021 Medical devices – Symbols to be used with information to be supplied by the manufacturer.









Symbol	Description
	Consult instructions for use or consult electronic instructions for use.
	Indicates the item is a medical device.
	Indicates the medical device manufacturer.

Symbol	Description
	<p>Indicates the country of manufacture of products and the date of manufacture (YEAR-MONTH-DAY).</p>
	<p>Indicates the manufacturer's catalogue number so that the medical device can be identified.</p>
	<p>Indicates the manufacturer's serial number so that a specific medical device can be identified.</p>
	<p>Storage temperature: Indicates the temperature limits to which the medical device can be safely exposed during storage.</p>
	<p>Operating temperature: Indicates the temperature limits to which the medical device can be safely exposed during operation.</p>
	<p>Indicates the range of humidity to which the medical device can be safely exposed.</p>
	<p>Indicates a medical device that needs to be protected from moisture.</p>
	<p>Indicates a medical device that needs protection from heat and radioactive sources.</p>
	<p>Indicates a medical device that can be broken or damaged if not handled carefully.</p>
	<p>Indicates that a medical device that should not be used if the package has been damaged or opened.</p>
	<p>Indicates a carrier that contains unique device identifier information.</p>
	<p>Indicates the entity distributing the medical device into the locale.</p>
	<p>The product should not be discarded as unsorted waste but must be sent to separate collection facilities for recovery and recycling.</p>

Symbol	Description
	Indicates that the manufacturer or importer affirms the goods' conformity with European health, safety, and environmental protection standards.

Unique Device Identifier Information

Each part of your CoMoveIT Smart device bears a Unique Device Identifier (UDI) number. The explanation of the UDI number is given in the Table below.

CoMoveIT Smart ECU   (01) (11) (21)	(01) Global Trade Item Number: 05430002911007 (11) Date of Manufacture: 6-digit indicating year, month and date in the following format: YYMMDD. For example, 230102 indicates YY: 2023, MM: January, DD: 2 nd day. (21) Serial Number: 9-digit number
CoMoveIT Smart H3   (01) (11) (21)	(01) Global Trade Item Number: 05430002911014 (11) Date of Manufacture: 6-digit indicating year, month and date in the following format: YYMMDD. For example, 230102 indicates YY: 2023, MM: January, DD: 2 nd day. (21) Serial Number: 9-digit number
CoMoveIT Smart F   (01) (11) (21)	(01) Global Trade Item Number: 05430002911038 (11) Date of Manufacture: 6-digit indicating year, month and date in the following format: YYMMDD. For example, 230102 indicates YY: 2023, MM: January, DD: 2 nd day. (21) Serial Number: 9-digit number
CoMoveIT Smart dF   (01) (11) (21)	(01) Global Trade Item Number: 05430002911045 (11) Date of Manufacture: 6-digit indicating year, month and date in the following format: YYMMDD. For example, 230102 indicates YY: 2023, MM: January, DD: 2 nd day. (21) Serial Number: 9-digit number

Intended Use

CoMoveIT Smart is intended to be used as a specialty input control device for powered wheelchairs. CoMoveIT Smart is intended to be used by individuals diagnosed with complex movement disorders, such as dystonia and choreoathetosis



in dyskinetic cerebral palsy. In general, all users with movement disorders who lack the ability to operate powered wheelchairs using conventional input devices.

Contraindications

CoMoveIT Smart must not be used by individuals who have a severe mental disability, and they are not able to follow and understand basic instructions, are diagnosed with as severe visual impairment, or suffer from severe epilepsy. The user must be able to estimate and correct the results of actions when operating the wheelchair.

Environmental Conditions

 **WARNING!**

Do not use your device under rain fall. Parts as the sensory system and the electronics may be damaged.

It is safe to operate your device in environmental temperature between -25°C / -13°F and 50°C / 122°F. We recommend not using your device in temperatures out of this range. The relative humidity of the environment must be between 10% and 90%. Do not use device under rainfall.

Device Description

General

CoMoveIT Smart captures pressure applied by the user to the head and foot pads of the device and translates them into driving commands for the powered wheelchair. CoMoveIT Smart embeds an adaptive algorithm which adapts in real time the required pressure needed to activate the wheelchair control system, based on the driving behavior of the user. The adaptive algorithm filters out uncontrolled, involuntary movements, and translates them into smooth driving control commands, resulting in a relaxed way of driving. CoMoveIT Smart is a plug and drive device that could offer independent mobility.

CoMoveIT Smart head array is mounted to the rear of the powered wheelchair, while the foot pads are mounted on the existing footrest. The position of the head array, as well as its sensor pads, can be adjusted to optimize user performance for drive and control activities.

CoMoveIT Smart works together with the PG Drives Technology R-net OMNI 2, PG Drives Technology R-net Input/Output Module, Q-Logic 3 EX Enhances Display, Curtis Instruments AG Display Module to provide control of the power wheelchair instead of an ordinary control device.

The operation of the wheelchair and its functions are controlled by applying pressure with head and feet to activate the force sensor arrays.

Head array adjustment mechanisms

The head array is adjustable to optimize its positioning based the needs of the user. The overall height of the head array can be adjusted using the rotary knob in Figure 1.

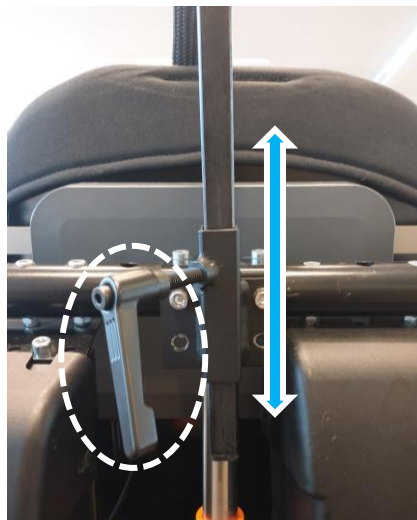

Figure 1. Rotary knob to adjust the height of the head array.

The depth of the head array can be adjusted via the rotary knob, which is positioned at the back. See Figure 2.

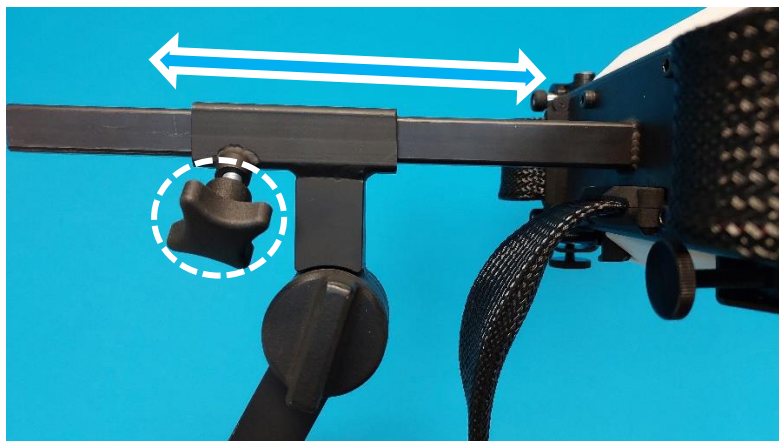

Figure 2. Rotary knob to adjust depth of the head array.

The inclination of the head array can be adjusted via the rotary knob which is positioned on the vertical adjuster. See Figure 3.

 **CAUTION!**
Do not overtighten the rotary knob for the inclination adjustment. The clamping mechanism provides enough grip. Overtightening the rotary knob might cause damage to it.



Figure 3. Rotary knob to adjust the inclination of the head array.

The opening angle of each of the side pads on the head array can be adjusted via rotary knobs positioned on the back as can be seen in Figure 4.

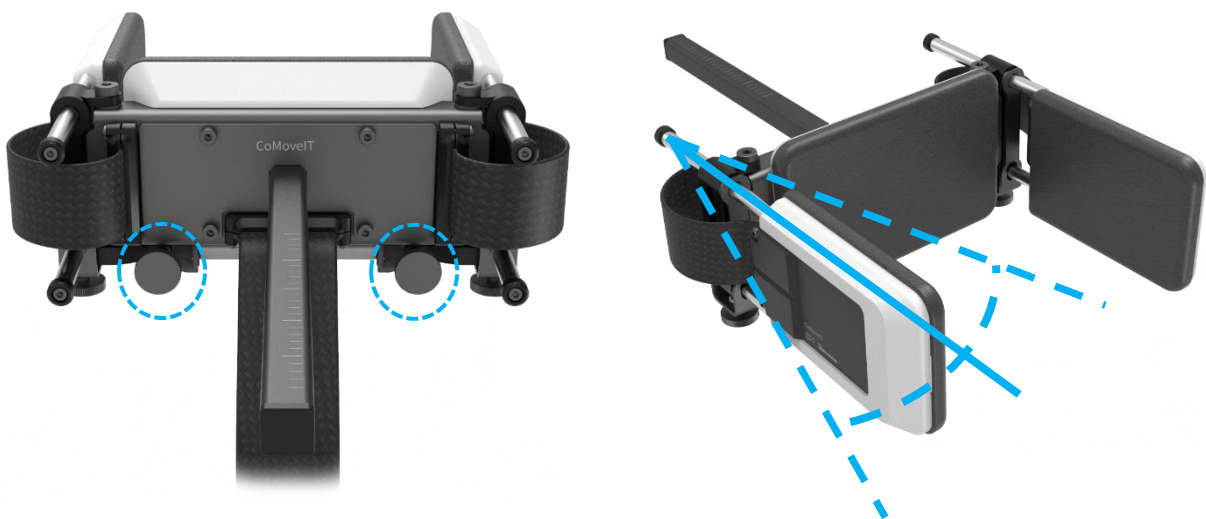

Figure 4. Rotary knobs to adjust the angle of the side head pads.

The depth of the side pads can be adjusted via rotary knobs positioned at the bottom of the head array. The depth of each pad can be adjusted by opening the rotary knob, shifting the pad and tightening the knob. See Figure 5.

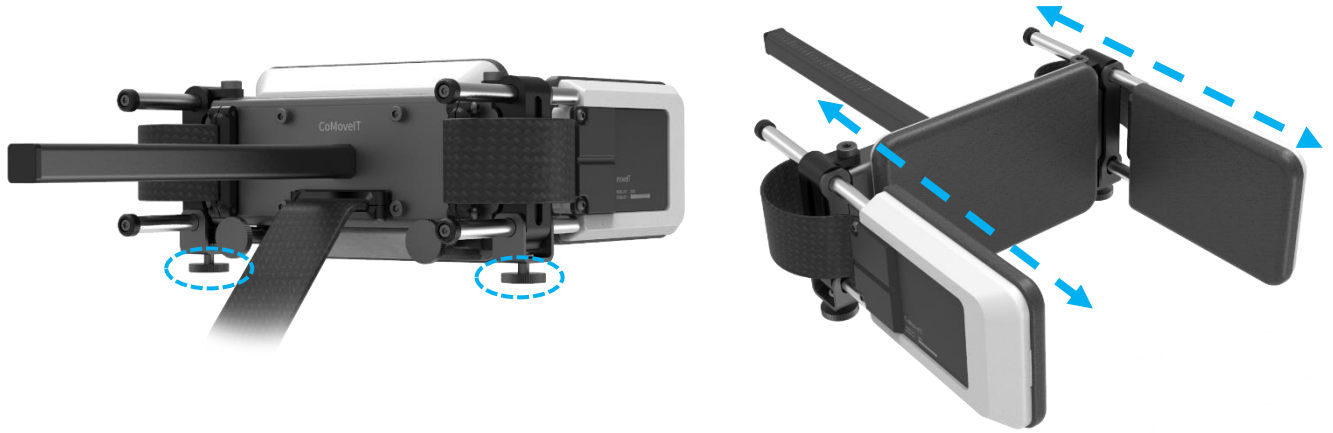

Figure 5. Rotary knobs to adjust the depth of the right and left side pads.



CAUTION!

Forcing any of the adjustment mechanisms to move other than as described above might damage the locking mechanisms.

Head array - right and left head pads



WARNING!

Do not press the head pads using sharp objects. This will affect the operation of the force sensor arrays. This may cause the wheelchair to drive in an unintended manner, creating a dangerous situation. If damage on the head pads is spotted, contact your local authorized distributor.

The right and left head pads have a force sensor array integrated in the cushion. See Figure 6.

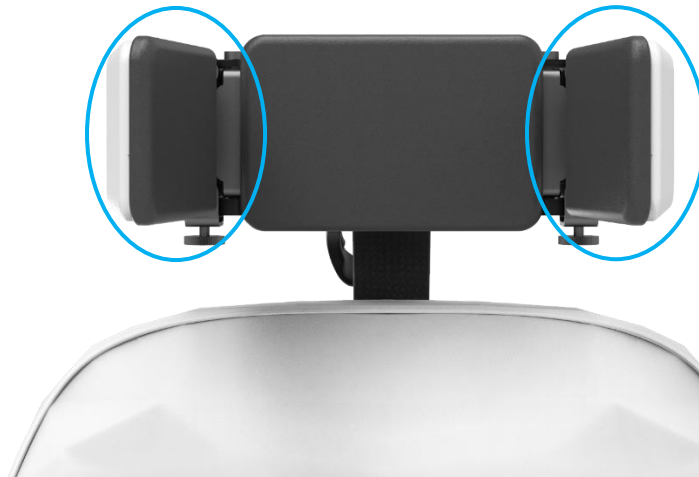

Figure 6. Left-side and right-side head pads where force sensor arrays are integrated.

Head array - back head pad

The back head pad has a force sensor array integrated in the cushion. See Figure 7.

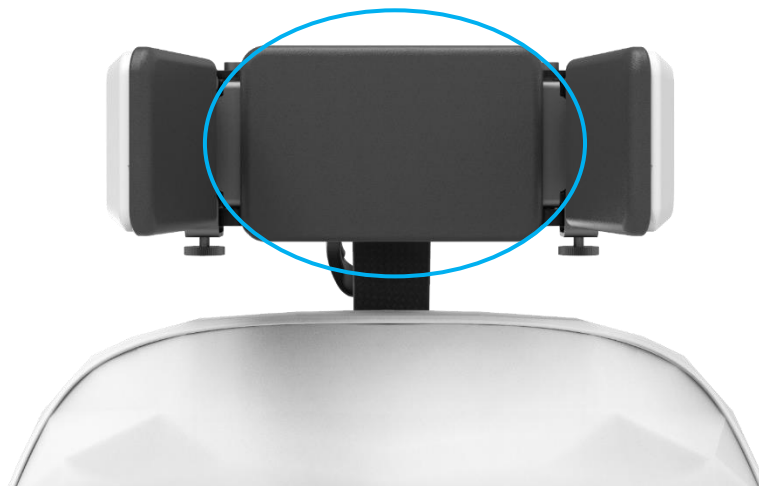



Figure 7. Back pad of the head array where a force sensor array is integrated.

Foot pads

	WARNING!
<p>Do not press the foot pads using sharp objects. This will affect the operation of the force sensor arrays. This may cause the wheelchair to drive in an unintended manner, creating a dangerous situation. If damage on the foot pads is spotted, contact your local authorized dealer.</p>	

Each of the foot pads of CoMoveIT Smart holds a force sensor array. The foot pads can be seen in Figure 8.

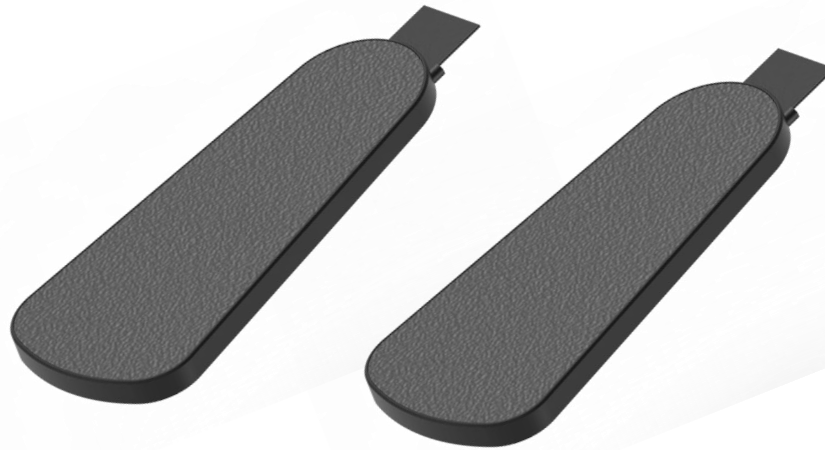



Figure 8. Foot pads of CoMoveIT Smart.

Dummy Foot Pad

The dummy foot pad of CoMoveIT Smart does not hold a force sensor array. It is used for symmetry purposes, so both feet of the user are on the same height.

Electronic Control Unit (ECU)

All parts of CoMoveIT Smart are connected to the ECU. The connection scheme can be seen in Figure 9.



CAUTION!

Do not tamper the connectors of the head array and footpads. Ask for help from a qualified engineer or someone with adequate knowledge to perform the adjustment in an expert manner or contact CoMoveIT if connection changes are required.

Connection Number	Operation
1	9-pin D-Sub connector – communication with the R-net Omni2 module or the R-net input/output module.
2	Connect the force sensor array for left turn.
3	Connect the force sensor array for right turn.
4	Connect the force sensor array for user switch.
5	Connect the force sensor array for driving.

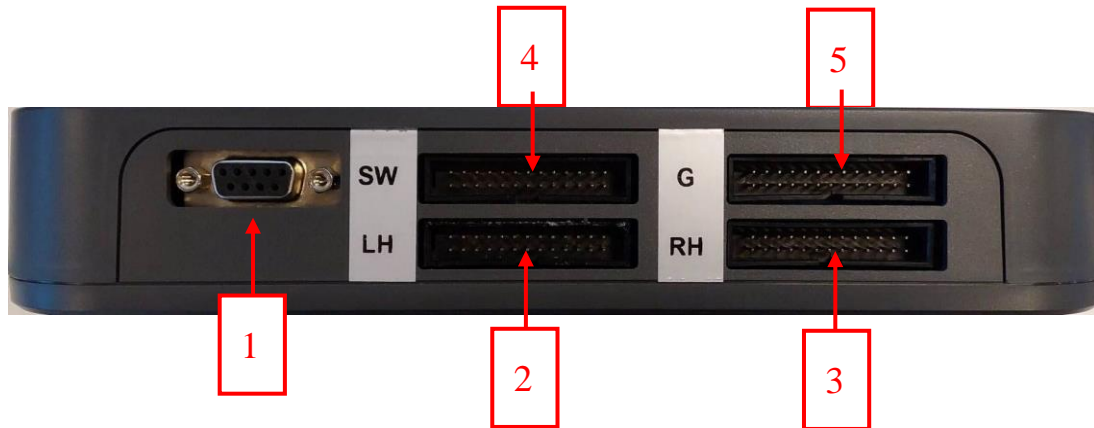

Figure 9. Connection panel.

CoMoveIT Smart installation



CAUTION!

Installation and removal of CoMoveIT Smart should not be attempted except by individuals familiar and experienced with the process as there may be multiple attaching devices used to secure safely and properly the CoMoveIT Smart and protect the cables.

1. Ensure that your wheelchair is switched off.
2. Install the vertical adjuster of CoMoveIT Smart to the holder of the back of the wheelchair seat and tighten the rotary knob. CoMoveIT Smart can fit in any 16 x 16 mm square holder. See Figure 10. CoMoveIT offers a specific mounting clamp for Permobil and Ottobock wheelchairs, that might fit other wheelchair brands as well. The mounting clamp must be purchased separately from your device.

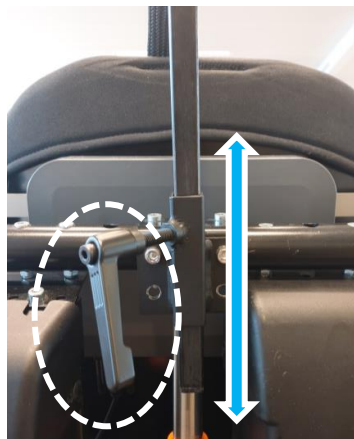

Figure 10. 16 x 16 mm square holder.

3. Fixate the cabling of the head array as close as possible the vertical adjuster and to the chassis or frame of the wheelchair or wheelchair seat. The use of tie wraps is highly recommended every 15 to 20 centimeters. See Figure 11.



Figure 11. Use of tie wraps.

4. Keep the cables of the head array away from sharp corners or objects and make sure there is enough tolerance on them when the vertical adjuster is extended.
5. Mount the foot pads of CoMoveIT Smart to the footrest of your wheelchair using the provided Velcro fastener. See Figure 12.



Figure 12. Velcro to attach foot pads to the wheelchair footrest.



CAUTION!

Inspect the Velcro of the foot pads once a month to ensure its functionality.

6. Fixate the cables of the foot pads as close as possible to the chassis, frame and/or seating of the wheelchair. The use of tie wraps is highly recommended every 15 to 20 centimeters.
7. Keep the cables of the foot pads away from sharp corners or objects and make sure there is enough tolerance on them when the footrest is extended.
8. Mount the Electronics Unit on the back of the seat using the four onboard M6 mounting points. It is highly recommended to keep the Electronics Control Unit within the physical limits of the wheelchair.
9. The CoMoveIT Smart Electronics Control Unit has four holes where blind nuts (included in the packaging) are placed. See Figure 13.



Figure 13. Blind nuts positioned in the four holes of the Electronics Control Unit.

10. As every wheelchair is unique there is not a general mounting bracket available. The dimensions in Figure 14, must be respected to mount the Electronics Control Unit. Use four M6 screws through the blind nuts to fixate the Electronics Control Unit. CoMoveIT offers specific mounting brackets for Permobil and Ottobock wheelchairs. The mounting cracket must be purchased separately from your device.

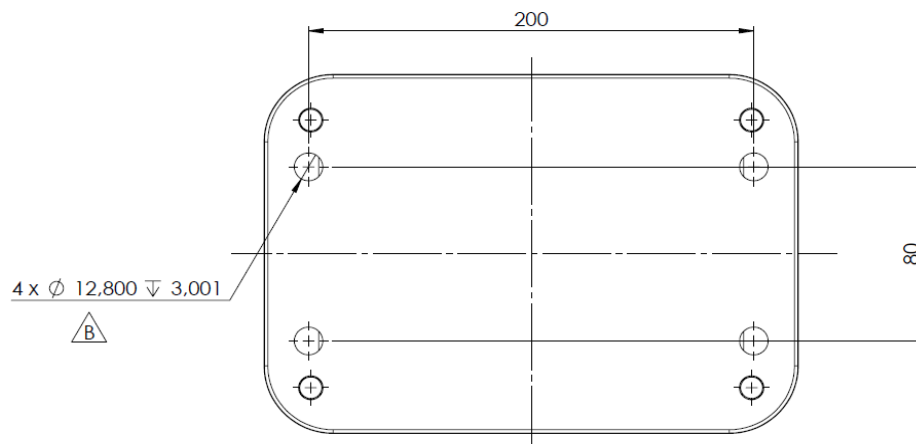

Figure 14. Mounting bracket dimensions.

11. Connect all sensor cables to CoMoveIT Smart Electronics Unit.

12. Connect and fasten the screws of CoMoveIT Smart DB9 connector to R-net Omni2 module.

CoMoveIT Smart removal

Perform the installation steps in reverse order.

1. Ensure that the wheelchair is switched off.
2. Remove any tie wraps for the cables of the head array and foot pads.
3. Unscrew and disconnect CoMoveIT Smart DB9 connector from the Rnet Omni2 module.
4. Disconnect all sensor cables to CoMoveIT Smart Electronics Unit by pulling firmly.
5. Remove the foot pads from the Velcro fastener.
6. Remove the head array by unlocking the vertical adjuster mechanism.
7. Remove the Electronics Unit by unscrewing the four M6 screws.

Configuration

R-net configuration



WARNING!

Programming should only be conducted by healthcare professionals with in-depth knowledge of programming R-net parameters. Incorrect programming could result in an unsafe set-up for you and your device.

Set the following parameters in the R-net programmer and write them to the controller of your powered wheelchair.

- **Profile Management** > Create three driving Profiles for CoMoveIT Smart. One for indoor driving, one for outdoor driving and one with in between speed settings.
- **Profile Management** > **Input Device Type**: set this parameter to **Omni**.

Profile Management	Profile 1	Profile 2	Profile 3
Profile Name	CoMoveIT Smart IN	CoMoveIT Smart M	CoMoveIT Smart OUT
Profile Enable	Yes	Yes	Yes
Mode Enable	[12345678]	[12345678]	[12345678]
Input Device Type	Omni	Omni	Omni
Input Device Subtype	All	All	All
Seat Reversal Profile	No	No	No
Allow Grab	Yes	Yes	Yes

- **Omni > Port:** select the Omni port in which CoMoveIT Smart is connected.
- **Omni > Ports > SID:** Set SID parameter to **3-Axis Switch**.
- **Omni > Ports > Switches:** Set **9-Way Detect** and **9-Way SID Switch Detect** to **Off**.

Omni			
Global			
Profiled			
Port			
Ports			
SID			
SID	CoMoveIT Smart IN	CoMoveIT Smart M	CoMoveIT Smart OUT
Switches	1	1	1
User Switch			
Switch Detect			
9-Way Detect	Port 1	Port 2	
Switch Long	3-Axis Switch	Proportional	
Switch Medium	Port 1	Port 2	
Switch Debounce	Normally Open	Normally Open	
Double Click	Off	Off	
User Switch Detect	Off	Off	
9-Way SID Switch Detect	Off	Off	

If you want to use head array configuration only:

- **Omni > Ports > Controls:** Set **Fwd /Rev Auto Toggle** to **Off**.

Controls	Port 1	Port 2
User Control	Menu	Menu
Return To	Menu	Drive
Timeout to Menu	0 s	0 s
Menu Navigation	Normal	Normal
Menu Scan Rate	0.00 s	0.00 s
Auto-repeat	Off	Off
Fwd / Rev Auto Toggle	Off	Off
Auto Toggle Time	3.00 s	2.00 s
Axis Direction Toggle Time	0.25 s	0.25 s
Actuator Selection	SID	SID
Actuator Axes	Normal	Normal

Operating Instructions

General

CoMoveIT Smart is designed for both indoors and outdoors use. For use indoors, normal care should be observed. Outdoors you must remember to move very slowly on steep inclined terrain and be extremely careful when moving over uneven surfaces. Consult the wheelchair's instruction manual for more information on the wheelchair's driving rules. The CoMoveIT Smart electronics translates the pressure applied by the head and feet to move the wheelchair as intended.

Configurations

The CoMoveIT Smart is offered in different configurations depending on the user's ability to use both feet. With each configuration you can drive forward, turn left or right and switch from forward to reverse. You can also enter the controller menu (OMNI2). The way how is different per configuration although turning left or right is mainly done with the left and right head pad.



WARNING!

The force sensor arrays integrated into the head and foot pads may inadvertently activate when exposed to rain or excessive moisture. This may cause the wheelchair to drive in an unintended manner, creating a dangerous situation.

Drive with right foot - Switch with left foot

In this configuration, you press the right foot pad to move forward, much like a gas pedal. Obviously turning left or right while driving can be done with the head pads. With your left foot you can activate the switch, which changes forward to reverse. By pressing the left pad, a little longer, you enter the controller menu (Figure 15). When preferred, the left and right foot functions can be swapped.



Figure 15. Drive with foot - Switch with foot configuration.

Drive with back head - Switch with one foot

A configuration for those who feel more comfortable driving forward by pressing the back head cushion is also possible. In this case, there is also a sensor built in at that place. Obviously, it can be used with the left and right pad at the same time in order to allow a smooth ride.

One of the feet, this can be left or right, is then used to control the switch, allowing to change from forward to reverse driving. By pressing the switch pad a little longer, you enter the controller menu (Figure 16).



Figure 16. Drive with back head - Switch with one foot.

Drive with one foot - Switch with back head

A last alternative is to drive forward with one foot, either left or right and use the back head cushion to activate the switch to change from forward to reverse or to enter the controller menu by pressing it a bit longer (Figure 17).



Figure 17. Drive with one foot- Switch with back head.

The force sensor arrays can be used to drive the wheelchair, navigate through the User menu, control the seat functions, control cursors, control external devices via the Omni2 module.

Auto safety check

The CoMoveIT Smart continuously checks its internal state and the state of the force sensor arrays.

Using your CoMoveIT



WARNING!

Do not attempt to operate a powered wheelchair with the CoMoveIT Smart without the assistance and training from a healthcare professional qualified for these activities. Do not attempt to independently operate a powered wheelchair with the CoMoveIT Smart until a qualified healthcare professional gives you the permission to do so.



WARNING!

The wheelchair must be fitted with an emergency stop function that is within the reach of the attendant.



WARNING!

The attendant or healthcare professional is expected to interpret the abilities of the user in terms of speed, reverse driving, reaching on/off, use of feet or not, cognitive and mental ability to use a powered wheelchair, in particular the safety mechanisms such as on/off button or an emergency button.

Your CoMoveIT Smart has the capability of operating all of the modes and functions of your powered wheelchair. Your healthcare provider and/or an experienced qualified engineer can tailor the operation of your CoMoveIT Smart to your individual needs. This may include changing the functionality and/or the position of the head support and foot support of CoMoveIT Smart. The method that you use to control your powered wheelchair using your CoMoveIT Smart will vary depending on how your provider has programmed the wheelchair R-net system.

Once the CoMoveIT Smart and the R-net system are set up to your needs, your local authorized distributor will train you on the operation of your CoMoveIT Smart. If you are unsure how to use your CoMoveIT Smart to control your powered wheelchair, it is advisable to consult your healthcare provider or local authorized distributor.

It is recommended that prior to using your CoMoveIT Smart in public places, crowded places, or in tight driving situations, that you try it out several times in an open space area that is familiar to you, so that you become comfortable with how your CoMoveIT Smart operates. The basic operation of your CoMoveIT Smart is described below.



Before using your CoMoveIT Smart for the first time, it is advised that the distributor or service engineer assists and explains the different possibilities and options to the user and/or the attendant. If needed, the distributor can fine-tune and make final adjustments to optimize your experience.

It is important that the user and the attendant are fully aware of how to use the system and the possible adjustments to optimize the use experience. Please inspect your device following the Maintenance section provided in this Instructions For Use document.

Straight forward driving

Ensure that your power wheelchair is in drive mode. Apply pressure on the back head pad or the foot pad that is responsible for the forward direction to move straight forward.

- Using the pad of the back head support :
To drive straight forward, press the back of your head to the back pad until the appropriate amount of pressure is applied. Resting your head on the back pad will provide you a support while the wheelchair is driving forward, as well as giving a continuous forward drive movement.
- Using the pad in one of the foot pads:
To drive straight forward, press on the foot pad until the appropriate amount of pressure is applied. Continuous activation of this foot pad will provide a continuous forward drive movement.

Stopping

Release the applied pressure from ALL force sensor arrays to stop the wheelchair's movement.



CAUTION!

An exception is when the wheelchair electronics have been programmed for latched driving. Then, it may be necessary to activate a reset switch to stop the wheelchair's movement. Contact your provider for more details if your wheelchair is setup for latched driving.

Turning right / turning left

Turn right by pressing to the right head pad without activating the forward or reverse pads. This will turn the wheelchair to the right in the smallest possible space.

Turn left by pressing to the left head pad without activating the forward or reverse pads. This will turn the wheelchair to the left in the smallest possible space.

Veer commands

During straight forward driving, it is possible to make a course-correction movement (veer) by pressing the left or right pad at the same time. Veer movements are useful when navigating a path that contains gentle curves. How sharp your electric-powered wheelchair turns during a veer is depending on your wheelchair type and is controlled by the profile and speed chosen.

Changing Operating Mode

The operating mode determines which wheelchair function the CoMoveIT Smart is controlling. The various operating modes can be driving, seat adjustment, mouse control, Bluetooth device control, and infrared device control. Which different modes your wheelchair is able to access is determined by the devices connected to your wheelchair and how R-net is programmed.

The CoMoveIT Smart can be used to switch between the operating modes by applying pressure long enough on the pad assigned to the switch function to enter the controller menu. Scrolling down is done with the pad responsible for the forward function and selecting or changing a value is done with the right head pad.

Reverse direction command



CAUTION!

The configuration of the reverse direction command can also be done via the R-net system by programming additional control modes. Please consult a qualified engineer.

To activate reverse driving, shortly press on the foot pad assigned to mode switch operation. Then drive reverse by using the forward force sensor array. To switch back to forward driving, shortly press on the foot pad assigned to mode switch operation.

Use this space to write potential user-specific instructions

Maintenance

CoMoveIT Smart is maintenance free, provided that is used in line with these Instructions for Use.

You must perform a monthly inspection of the following parts and ensure that:

- All bolts and screws are tightened.
- There is no damage in the cabling of the head array, footpads and electronic control unit.
- There is no damage in the plugs of the head array and footpads.
- There is no damage in the connectors of the electronic control unit.
- There is no excessive wear to any parts of the device.
- There is no excessive wear in the cushions of the head array.
- There is no excessive wear in the cover of the foot pad.
- The fixation Velcro of the footpads offers an adequate grip.

We advise to have at least a yearly check of your wheelchair and the subsystems of your wheelchair conducted by a qualified service engineer.

Maintenance is important for the safety and performance of your CoMoveIT Smart.

Cleaning



WARNING!

Never spill water or use a water hose to clean CoMoveIT Smart parts as the sensory system and the electronics may be damaged.



CAUTION!

It is recommended to use a soap-water solution for the cleaning of your CoMoveIT Smart. Do not use aggressive cleaning agents.

It is recommended to clean plastic and metal parts of CoMoveIT Smart head array using a damp cloth. In case of excess dirt concentration, a soap water solution can be used. Always wipe dry after cleaning.

The pads of the head array must be cleaned with a damp cloth using water or a soap water solution once a week. During hot weather conditions, it is recommended to clean them every day since sweat concentration might be increased. Gently, wipe dry after cleaning.

The pads of the feet support must be cleaned with a damp cloth using water or a soap water solution. Wipe dry after cleaning. In case excessive wear is spotted on the foot pads of CoMoveIT Smart, please contact your local authorized dealer.

Moisture might potentially affect the operation of force sensor arrays, make sure that all parts and surfaces of CoMoveIT Smart are completely dry before using it to operate the wheelchair.

Cleaning accomplishes clean device surfaces, especially on the head array cushions where your head is in contact. Cleaning contributes to the overall hygienic condition of your device. Failure to clean on a regular basis, might cause excessive sweat and dirt build up on the cushion of the head array.

Storage

Your device can be stored in environmental temperatures between -40°C / -40°F and 65°C / 149°F for a few days. It is recommended not to store your device for longer term in these temperature. Ideally, store your device in room temperature. During storage make sure that your device is protected from rain or liquid flow. Keep your device away from direct sunlight and protect the head and footpads from sharp objects. Always conduct a functional check before using your device after a long-term storage.

Troubleshooting

You must stop using the device immediately if operating problems occur. If your device does not react check the following:

- Make sure that the sensors of the head array (and) footpads are connected to the ECU.
- Make sure that the cable between CoMoveIT Smart and the Omni module is connected.
- Make sure that the cable between CoMoveIT Smart and the Omni module is connected to the programmed port of OMNI2 (PORT1 or PORT 2).
- If an error code appears on the Omni2 display, please consult the following Table. Errors appear as text displayed on the OMNI 2 display as text messages accompanied by an ID code. Do not try to solve this problem yourself, please ask for support from your local distributor.

R-net Error Codes

Error ID	Error Name	Text Displayed on OMNI	Remedy #
0704	12V Supply Failure		1
0808	Joystick Error	Joystick Error	2
080A	Joystick Error	Joystick Error	2
080B	Joystick Error	Joystick Error	2
0905	SID Detached	SID Disconnected	3
09B1	Omni Input	Omni Input Module Error	4
0E00	Joystick Error	Joystick Error	2
0E02	Joystick Error	Joystick Error	2
1E07	User Switch Detached	Switch Detached	5
1E40	Omni Input	Omni Input Module Error	6
1E50/1E54	Omni Input	Omni Input Module Error	7
1E72	Omni Input	Omni Input Module Error	8
2F01	Center Joystick	Center Joystick	2
8146	Omni Input	Omni Input Module Error	9

Remedy 1

Perform the following steps:

- Check the condition and charge level of the batteries.
- Ensure the connections between the batteries and power module are tight and the cables are not damaged.
- Ensure the connections between the motors and power module are tight and the cables are not damaged.
- Remove and Restore power to the Drive System by turning the Circuit Breaker off/on or by disconnecting the Main Fuse from the batteries and reconnecting it.

Remedy 2

The most common cause of this error is if the joystick is deflected away from center, or a sensor of CoMoveIT Smart is pressed before or during the time the control System is switched on. The joystick displaced screen will be displayed for 5 seconds, if the pressure from a sensor of CoMoveIT Smart is not released within that time, then an error is registered.

- Ensure that any sensor of CoMoveIT Smart is not pressed before or during the time you power on the wheelchair. Power cycle your wheelchair.
- If the error persists, in the Rnet programmer go to: **Omni > Ports > SID:** Set SID parameter to **3-Axis Switch**.

Remedy 3

- Check the cable between the Omni and CoMoveIT Smart.
- If the error persists, in the R-net programmer go to: **Omni > Ports > Switches:** Set **9-Way Detect** to **Off**.
- If there is switch connected to OMNI 2 and e-stop message is displayed on the Omni2 display during power up, in the R-net programmer go to: **Omni > Switches:** Set **User Switch** to **Normally Open** or **Normally Closed**, based on the type of switch you are using.

Remedy 4

- In the R-net programmer go to: **Omni > Switches >:** Set **9-Way Detect** to **Off**. Set **9-Way Detect** to **Off**.

Remedy 5

The Omni has detected that the User Switch has become disconnected from the U1 or U2 port of the Omni.

- Check all cables and connectors between the Omni ports and the User Switch. If the trip is still present after the above checks have been made, then the User Switch may be defective. Try replacing it with a known good switch.



- If it is required to use the Omni without a User Switch being connected, in the R-net programmer go to: Omni > Switches: Set **Switch Detect** to **Off**.
- Plug a switch in the Omni U port or set **Switch Detect** to **Off** in the R-net Programmer.

Remedy 6

- In the R-net programmer go to: **Omni > Switches >**: Set **User Switch Detect** to **Off**.

Remedy 7

- In the R-net programmer go to: **Omni > Switches >**: Set **9-Way SID Switch Detect** to **Off**.

Remedy 8

- Check the cable between the Omni and CoMoveIT Smart.
- Reconnect the cable or replace the cable.

Remedy 9

- Check the cable between the Omni and CoMoveIT Smart.
- If the error persists, reconnect the cable or replace the cable.

Summary

This summary is not intended to replace complete user instructions. You must read the entire Instructions for Use before you operate your CoMoveIT Smart.

CoMoveIT Smart must not be used by individuals who have a severe mental disability, severe visual impairment, or suffer from severe epilepsy. The user must be able to estimate and correct the results of actions when operating the wheelchair.

Do not attempt to operate a powered wheelchair with the CoMoveIT Smart without the assistance and training from a healthcare professional qualified for these activities. Do not attempt to independently operate a powered wheelchair with the CoMoveIT Smart until a qualified healthcare professional gives you the permission to do so.

The wheelchair must be fitted with an emergency stop function that is within the reach of the attendant. You must stop using the device immediately if operating problems occur.

Do not use your device in rainy weather conditions. This may cause the wheelchair to drive in an unintended manner, creating a dangerous situation. Do not press the head pads and foot pads of your device using sharp objects. This will affect the operation of the force sensor arrays.



Programming of the R-net parameters of your wheelchair is important to be fine-tuned based on your needs and should only be conducted by skilled professionals with in-depth knowledge.

Before using your CoMoveIT Smart for the first time, you and your attendant must be fully aware of how to use the system and the possible adjustments to optimize the use experience. Connect your head array (and) footpad(s) to the electronic control unit. Then, connect the electronic control unit to the Omni2 module.

To use your CoMoveIT Smart, power on you wheelchair and select the appropriate driving profile for your driving environment (indoors or outdoors). To drive forward, apply pressure to the head or foot pad assigned as gas pedal. To steer right, apply pressure to the head or foot pad assigned as right steer. To steer left, apply pressure to the head or foot pad assigned as left steer. To select reverse driving, press short on the head or foot pad assigned as user switch. To drive backwards, ensure that reverse driving is selected and apply pressure to the head or foot pad assigned as gas pedal. To access the Omni 2 User Menu, press long on the head or foot pad assigned as user switch, and the User Menu will appear. The User Menu allow you to control your seating, adjust speed, chose driving profile, control Bluetooth devices and peripherals.

Please inspect that there no damage in the following parts of your device once a month: bolts and screws, cabling, cable plugs, connectors, head cushions, foot cover, and Velcro fixations. Please clean the head array cushions, plastic and metal parts of your device with a damp cloth using water or a soap water solution once a week. Gently, wipe dry after cleaning.

Use this space to write phone numbers for help in case of emergency.

Technical specifications

SPECIFICATIONS	
System Name	CoMoveIT Smart
Interface Connector	Female 9-pin D-sub for connection with interface module
Interfaces	PG Drives Technology R-net OMNI 2, PG Drives Technology R-net Input/Output Module, Q-Logic 3 EX Enhanced Display, Curtis Instruments AG Display Module
Operating Voltage	12V DC
Maximum Current Usage	66 mA
Omni SID Control Type	3-axis Switched Input or 4-axis Switched Input
Force Sensor Array Connector	IDC Connector, 26 Contacts



CoMoveIT NV

**Baron Ruzettelaan 5/1.1
Assebroek (Bruges), 8310
Belgium**

Email: info@comoveit.com

Your local distributor



© 2022 CoMoveIT NV (BE)

Version 1.3, 2024-24-07

Article no.: CM0001-IFU-EN